

# Metric Locating, Positioning Blocks & Fixture Keys

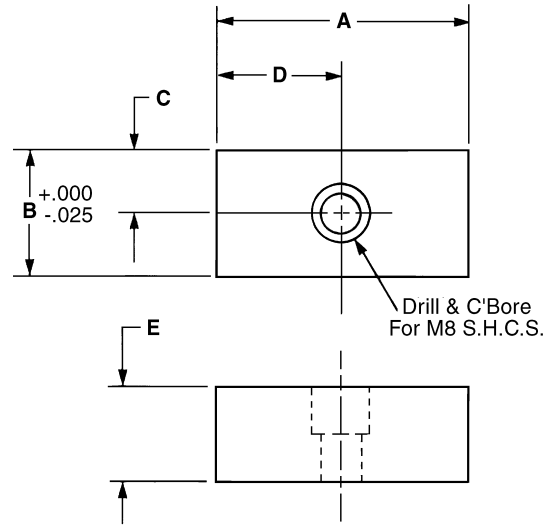

Metric

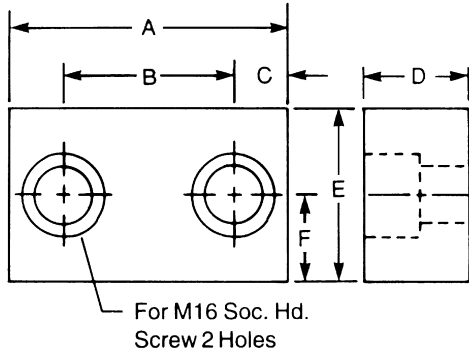

CAD FILE NAME	PART NUMBER	A	B	C	D	E	F
EHM049	EHM049	80.0	50.0	15.0	30.0	50.0	25.0
EHM050	EHM050	130.0	100.0	15.0	30.0	50.0	25.0
EHM051	EHM051	105.0	75.0	15.0	30.0	50.0	25.0

CAD FILE NAME	PART NUMBER	A	B	C	D	E
EM428	EM428	50	25	12.5	25.0	18
EM429	EM429	50	25	12.5	25.0	12
EM430	EM430	75	25	12.5	37.5	18
EM431	EM431	75	25	12.5	37.5	25

## CAD File Name EHM052 Part No. EHM052

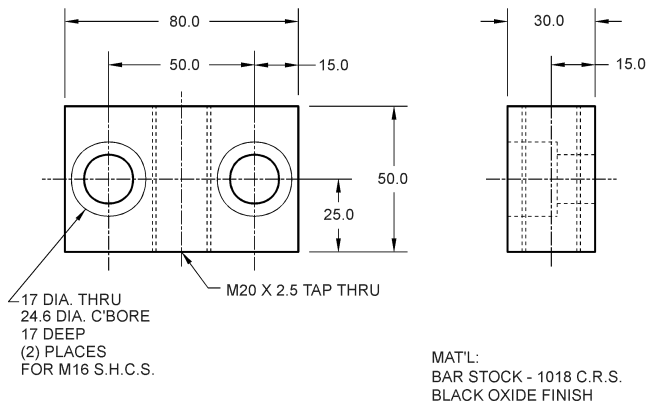

## CAD File Name EHM053 Part No. EHM053

