

Metric Leveling Jacks

Features:

- Single Point Leveling and Hold Down through Center
- Adjustable
- Standard Product
- Off-Shelf Delivery
- Full Range of Sizes

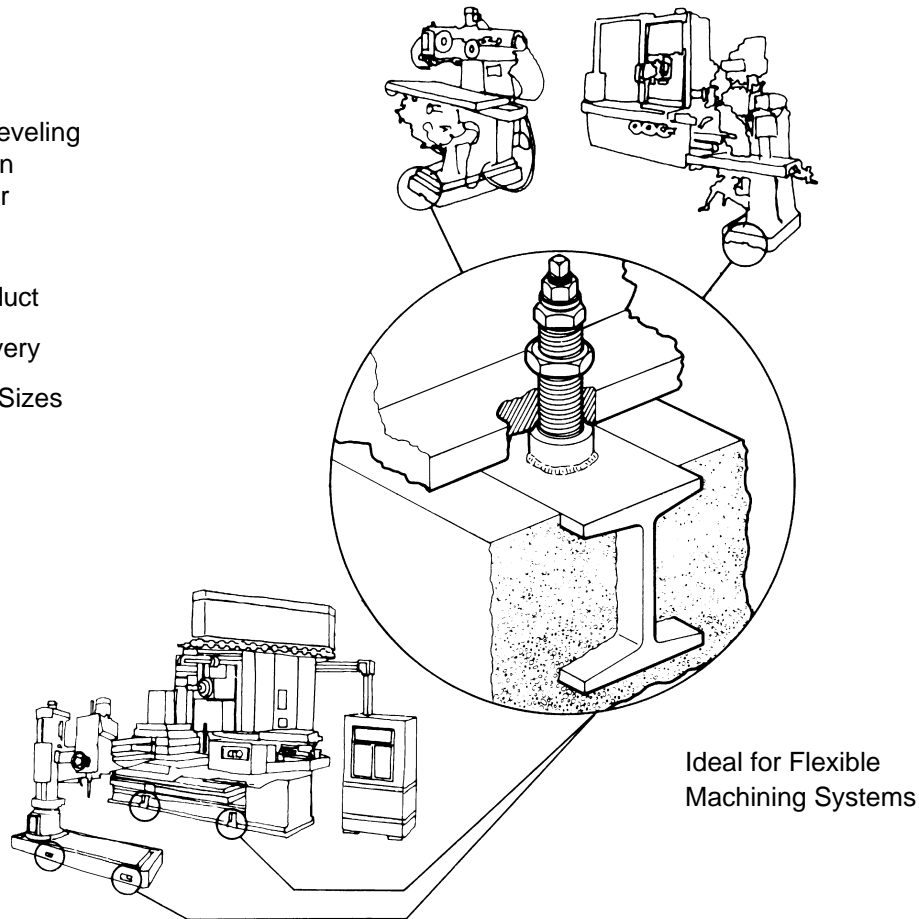

Coaxial Leveling and Anchoring for:

- Mills
- Lathes
- Transfer Lines
- Machining Center
- Boring Mills
- Grinders
- Broaches
- Fixtures
- Screw Machines
- Assembly Machines
- Stamping Presses
- Drill Presses



Metric Leveling Jacks



CAD FILE NAME	PART NUMBER	DESCRIPTION	A	B	C	D	E	F
2050	EMLJ-2050-F	BODY AND JAM NUT ONLY	M20 x 1.5	50	13	38	28.6	10.3
2050	EMLJ-2050-C		M20 x 2.5	50	13	38	28.6	10.3
2475	EMLJ-2475-F		M24 x 2	75	16	38	28.6	14.2
2475	EMLJ-2475-C		M24 x 3	75	16	38	28.6	14.2
3010	EMLJ-3010-F		M30 x 2	100	16	38	41.3	14.2
3010	EMLJ-3010-C		M30 x 3.5	100	16	38	41.3	14.2
3015	EMLJ-3015-F		M30 x 2	150	16	38	41.3	14.2
3015	EMLJ-3015-C		M30 x 3.5	150	16	38	41.3	14.2
3610	EMLJ-3610-F		M36 x 3	100	16	57	41.3	22.2
3610	EMLJ-3610-C		M36 x 4	100	16	57	41.3	22.2
3615	EMLJ-3615-F		M36 x 3	150	16	57	41.3	22.2
3615	EMLJ-3615-C		M36 x 4	150	16	57	41.3	22.2
3910	EMLJ-3910-F		M39 x 3	100	16	57	41.3	22.2
3910	EMLJ-3910-C		M39 x 4	100	16	57	41.3	22.2
3915	EMLJ-3915-F		M39 x 3	150	16	57	41.3	22.2
3915	EMLJ-3915-C		M39 x 4	150	16	57	41.3	22.2

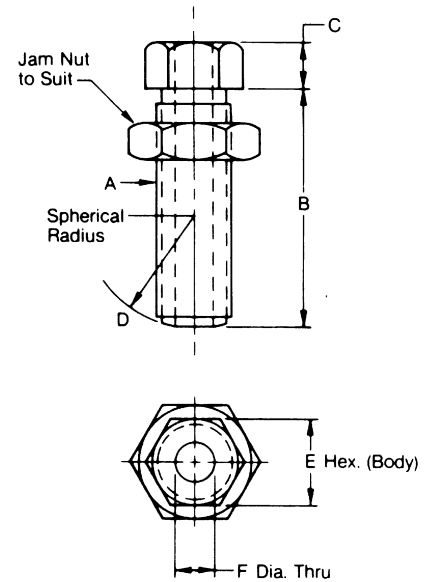

CAD FILE NAME	PART NUMBER	DESCRIPTION	G
2050A	EMLJ-2050-FA	BODY JAM NUT STUD HEX NUT FLAT WASHER SPHERICAL WASHER	M8 x 1.25 x 100
2050A	EMLJ-2050-CA		M8 x 1.25 x 100
2475A	EMLJ-2475-FA		M12 x 1.75 x 140
2475A	EMLJ-2475-CA		M12 x 1.75 x 140
3010A	EMLJ-3010-FA		M12 x 1.75 x 160
3010A	EMLJ-3010-CA		M12 x 1.75 x 160
3015A	EMLJ-3015-FA		M12 x 1.75 x 210
3015A	EMLJ-3015-CA		M12 x 1.75 x 210
3610A	EMLJ-3610-FA		M20 x 2.5 x 170
3610A	EMLJ-3610-CA		M20 x 2.5 x 170
3615A	EMLJ-3615-FA		M20 x 2.5 x 220
3615A	EMLJ-3615-CA		M20 x 2.5 x 220
3910A	EMLJ-3910-FA		M20 x 2.5 x 170
3910A	EMLJ-3910-CA		M20 x 2.5 x 170
3915A	EMLJ-3915-FA		M20 x 2.5 x 220
3915A	EMLJ-3915-CA		M20 x 2.5 x 220

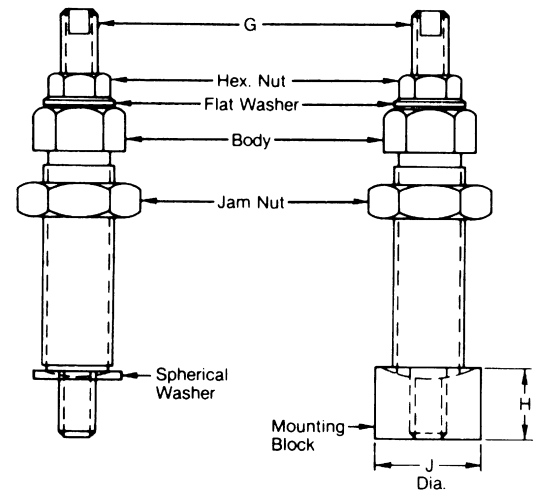

CAD FILE NAME	PART NUMBER	DESCRIPTION	H	J
2050AM	EMLJ-2050-FAM	BODY JAM NUT STUD HEX NUT FLAT WASHER MOUNTING BLOCK	19	38
2050AM	EMLJ-2050-CAM		19	38
2475AM	EMLJ-2475-FAM		25.4	38
2475AM	EMLJ-2475-CAM		25.4	38
3010AM	EMLJ-3010-FAM		31.8	63.5
3010AM	EMLJ-3010-CAM		31.8	63.5
3015AM	EMLJ-3015-FAM		31.8	63.5
3015AM	EMLJ-3015-CAM		31.8	63.5
3610AM	EMLJ-3610-FAM		31.8	63.5
3610AM	EMLJ-3610-CAM		31.8	63.5
3615AM	EMLJ-3615-FAM		31.8	63.5
3615AM	EMLJ-3615-CAM		31.8	63.5
3910AM	EMLJ-3910-FAM		31.8	63.5
3910AM	EMLJ-3910-CAM		31.8	63.5
3915AM	EMLJ-3915-FAM		31.8	63.5
3915AM	EMLJ-3915-CAM		31.8	63.5