

# Leveling Screws

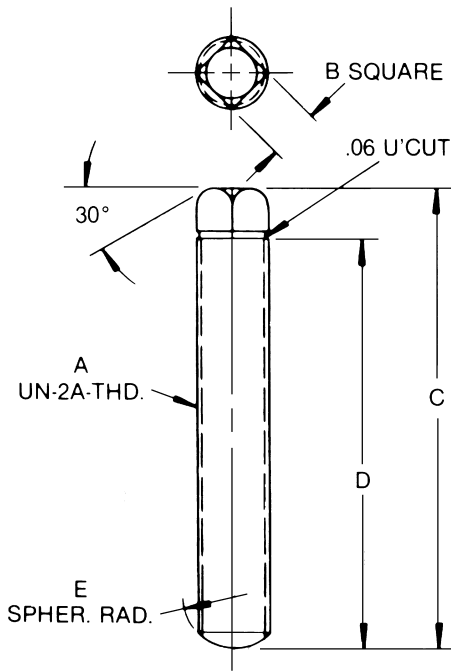

CAD FILE NAME	PART NUMBER	A	B	C	D	E
E45001	E45001	3/4-10	.53	7.57	7.00	—
E45002	E45002	1-8	.71	7.75	7.00	—
E45003	E45003	1-1/4-12	.88	7.94	7.00	—
E45004	E45004	1-1/2-12	1.06	8.12	7.00	—
E45005	E45005	3/4-10	.53	7.06	6.50	.56
E45006	E45006	1-8	.71	7.25	6.50	.75
E45007	E45007	1-1/4-12	.88	7.44	6.50	.94
E45008	E45008	1-1/2-12	1.06	7.62	6.50	1.12

LEVELING SCREW  
 MAT'L MFG. STD.  
 HEAT TREAT  
 ROCK "C" 48-52

# Leveling Screw-Mounts

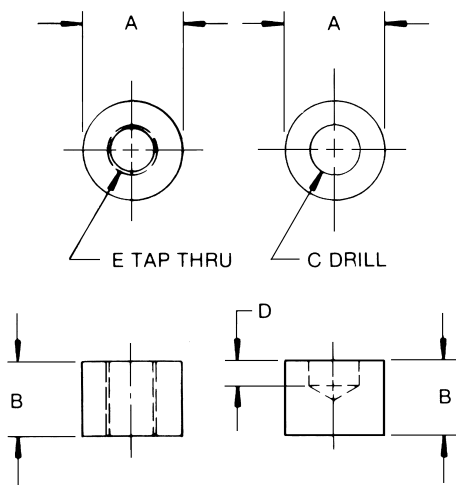

CAD FILE NAME	PART NUMBER	A	B	C	D	E
E45011	E45011	2-1/2	1.50	7/8	1/4	—
E45012	E45012	2-1/2	1.50	1-1/8	1/4	—
E45013	E45013	3	1.50	1-3/8	1/4	—
E45014	E45014	3-1/2	1.50	1-5/8	1/4	—
E45015	E45015	2-1/2	1.50	—	—	3/4 - 10
E45016	E45016	2-1/2	1.50	—	—	1 - 8
E45017	E45017	3	1.50	—	—	1-1/4 - 12
E45018	E45018	3-1/2	1.50	—	—	1-1/2 - 12

- |        |        |
|--------|--------|
| E45015 | E45011 |
| E45016 | E45012 |
| E45017 | E45013 |
| E45018 | E45014 |