

Adjusting Blocks



DESIGN FEATURES

- Rugged Steel Construction
- Ground Width for Keying to Machine Base
- Adjust and Hold Down from One Unit
- Use Several Units for Multi Axis Adjustment
- Special Versions Available

CAD File Name E3006

Part No. E-3006

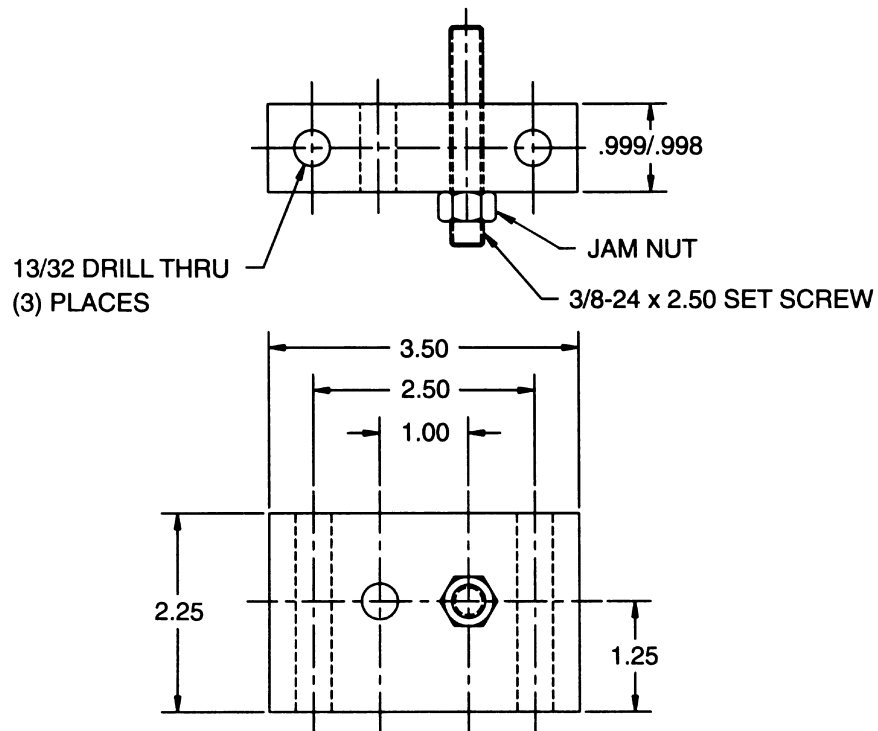

Adjusting Blocks

CAD File Name E425
Part No. E425

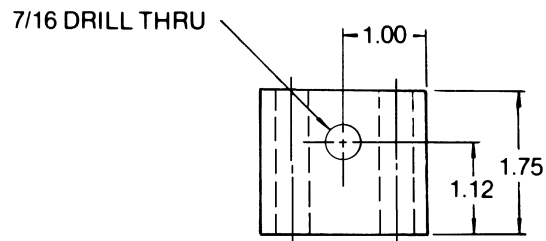
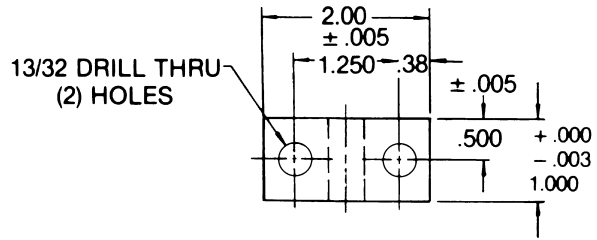

FINISH: BLACK OXIDE

CAD File Name E426
Part No. E426

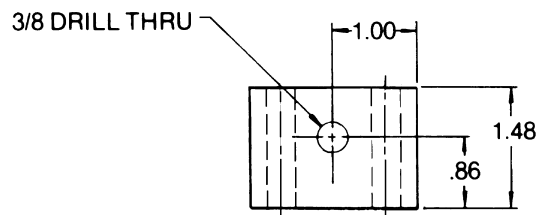
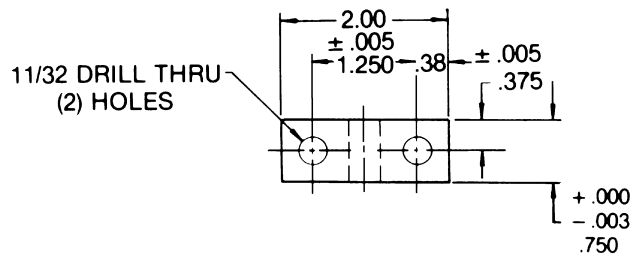

FINISH: BLACK OXIDE

CAD File Name E427
Part No. E427 Spacer

