

Leveling Jacks

Features:

- Single Point Leveling and Hold Down Through Center
- Adjustable
- Standard Product
- Off-Shelf Delivery
- Full Range of Sizes

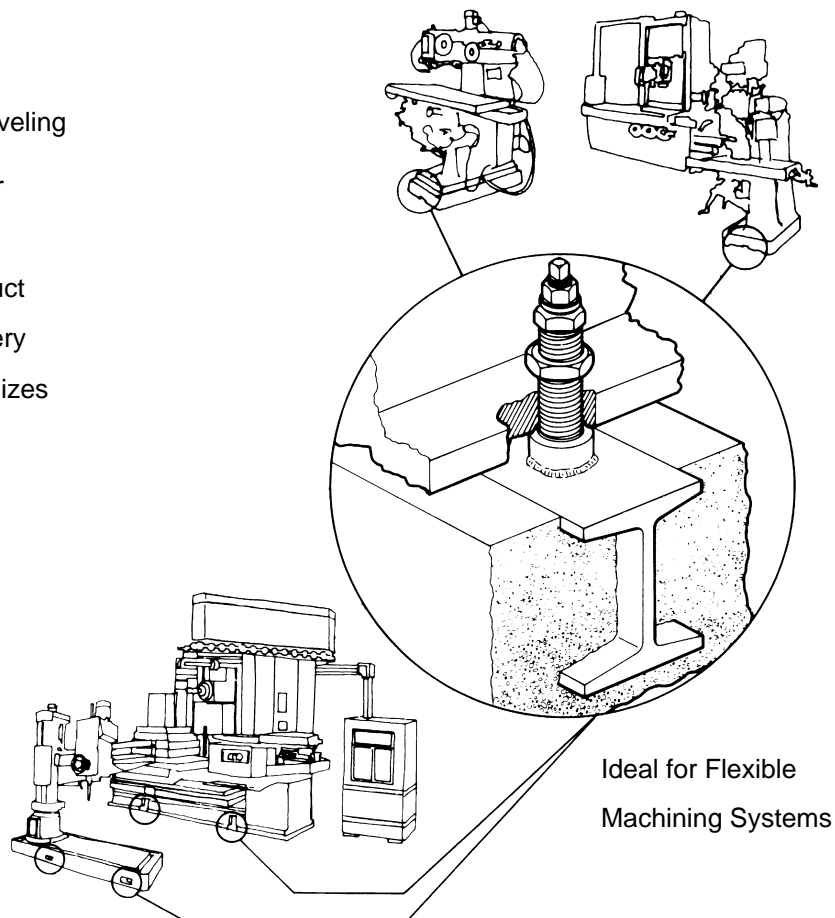

Coaxial Leveling and Anchoring for:

- | | |
|--|--|
| <input type="checkbox"/> Mills | <input type="checkbox"/> Broaches |
| <input type="checkbox"/> Lathes | <input type="checkbox"/> Fixtures |
| <input type="checkbox"/> Transfer Lines | <input type="checkbox"/> Screw Machines |
| <input type="checkbox"/> Machining Centers | <input type="checkbox"/> Assembly Machines |
| <input type="checkbox"/> Boring Mills | <input type="checkbox"/> Stamping Presses |
| <input type="checkbox"/> Grinders | <input type="checkbox"/> Drill Presses |



Leveling Jacks

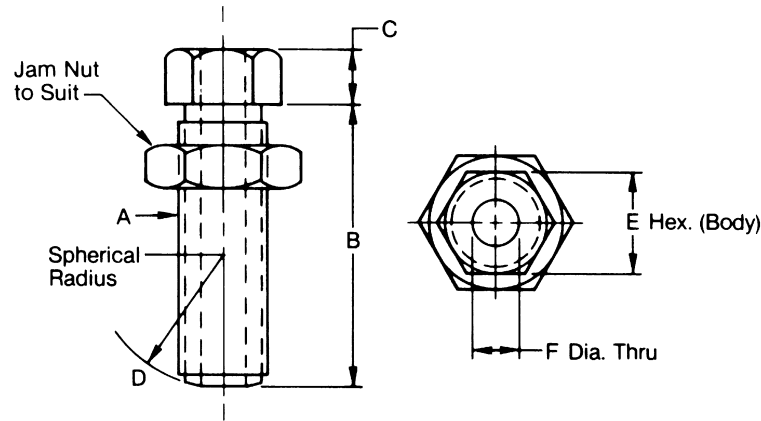

CAD FILE NAME	PART NUMBER	DESCRIPTION	A	B	C	D	E	F
LJ7502	ELJ-7502	BODY AND JAM NUT ONLY	3/4 - 16	2 - 1/8	1/2	1 - 1/2	1 - 1/8	13/32
LJ1003	ELJ-1003		1 - 14	3 - 3/16	5/8	1 - 1/2	1 - 1/8	9/16
LJ1123	ELJ-1123		1 - 1/8 - 12	3 - 5/8	5/8	1 - 1/2	1 - 5/8	9/16
LJ1125	ELJ-1125		1 - 1/8 - 12	5 - 3/8	5/8	1 - 1/2	1 - 5/8	9/16
LJ1503	ELJ-1503		1 - 1/2 - 12	3 - 5/8	5/8	2 - 1/4	1 - 5/8	7/8
LJ1505	ELJ-1505		1 - 1/2 - 12	5 - 3/8	5/8	2 - 1/4	1 - 5/8	7/8

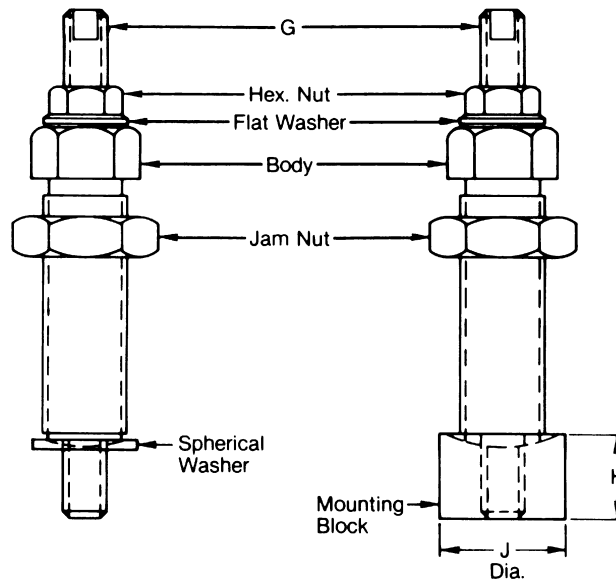

CAD FILE NAME	PART NUMBER	DESCRIPTION	G	CAD FILE NAME	PART NUMBER	DESCRIPTION	H	J
LJ7502A	ELJ-7502-A	BODY JAM NUT STUD HEX NUT FLAT WASHER SPHERICAL WASHER	3/8 - 16 x 4-1/4	LJ7502M	ELJ-7502-AM	BODY JAM NUT STUD HEX NUT FLAT WASHER MOUNTING BLOCK	3/4	1-1/2
LJ1003A	ELJ-1003-A		1/2 - 13 x 7	LJ1003M	ELJ-1003-AM		1	1-1/2
LJ1123A	ELJ-1123-A		1/2 - 13 x 7-1/2	LJ1123M	ELJ-1123-AM		1-1/4	2-1/2
LJ1125A	ELJ-1125-A		1/2 - 13 x 8-1/2	LJ1125M	ELJ-1125-AM		1-1/4	2-1/2
LJ1503A	ELJ-1503-A		3/4 - 10 x 7-1/2	LJ1503M	ELJ-1503-AM		1-1/4	2-1/2
LJ1505A	ELJ-1505-A		3/4 - 10 x 9	LJ1505M	ELJ-1505-AM		1-1/4	2-1/2

Leveling Screws

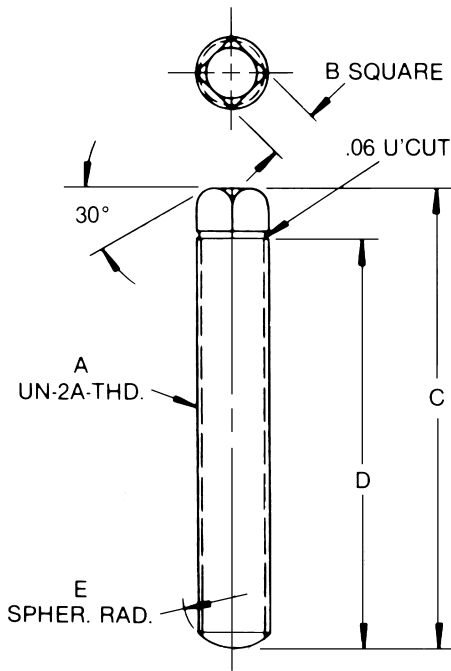

CAD FILE NAME	PART NUMBER	A	B	C	D	E
E45001	E45001	3/4-10	.53	7.57	7.00	—
E45002	E45002	1-8	.71	7.75	7.00	—
E45003	E45003	1-1/4-12	.88	7.94	7.00	—
E45004	E45004	1-1/2-12	1.06	8.12	7.00	—
E45005	E45005	3/4-10	.53	7.06	6.50	.56
E45006	E45006	1-8	.71	7.25	6.50	.75
E45007	E45007	1-1/4-12	.88	7.44	6.50	.94
E45008	E45008	1-1/2-12	1.06	7.62	6.50	1.12

LEVELING SCREW
 MAT'L MFG. STD.
 HEAT TREAT
 ROCK "C" 48-52

Leveling Screw-Mounts

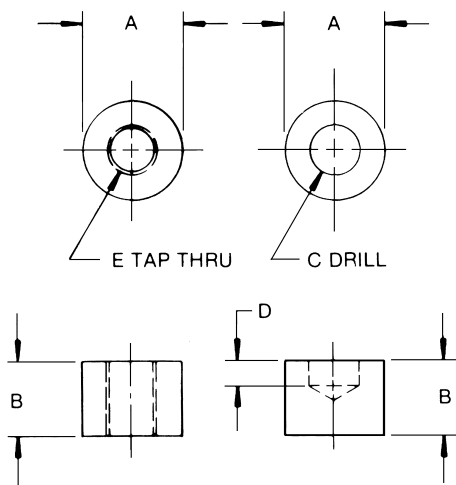

CAD FILE NAME	PART NUMBER	A	B	C	D	E
E45011	E45011	2-1/2	1.50	7/8	1/4	—
E45012	E45012	2-1/2	1.50	1-1/8	1/4	—
E45013	E45013	3	1.50	1-3/8	1/4	—
E45014	E45014	3-1/2	1.50	1-5/8	1/4	—
E45015	E45015	2-1/2	1.50	—	—	3/4 - 10
E45016	E45016	2-1/2	1.50	—	—	1 - 8
E45017	E45017	3	1.50	—	—	1-1/4 - 12
E45018	E45018	3-1/2	1.50	—	—	1-1/2 - 12

- | | |
|--------|--------|
| E45015 | E45011 |
| E45016 | E45012 |
| E45017 | E45013 |
| E45018 | E45014 |