

# Trunnion Block

**NOTE:**

Trunnions are provided with Dixon CJ Bearings, a non-metallic bearing that excels under high loads and provides dry lubrication with high reliability.

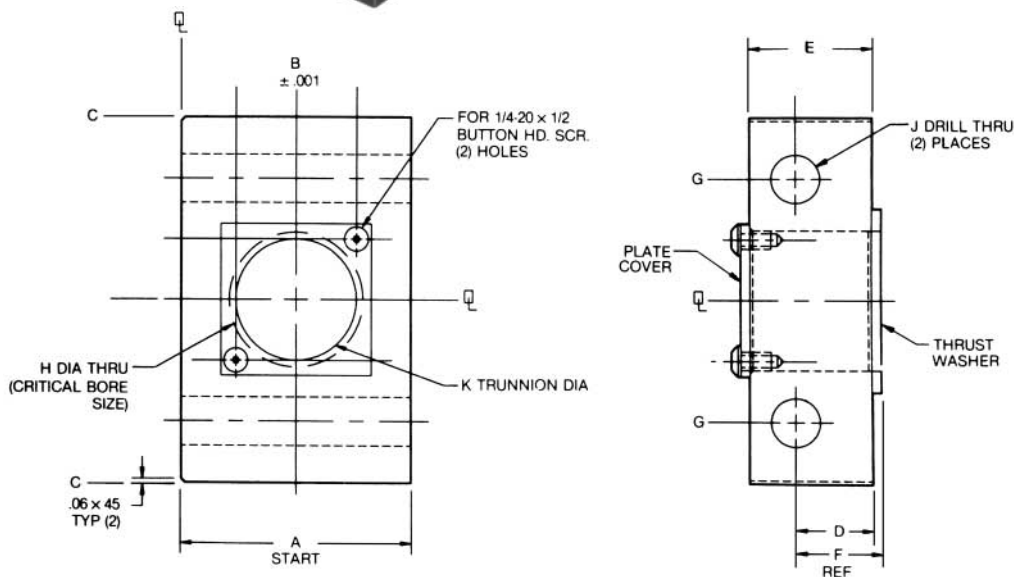

CAD FILE NAME	PART NUMBER	A	B	C	D	E	F	G	H	J	K
E1501M-P	<b>E1501</b>	2.60	1.300	1.999	.625	1.00	.750	1.500	1.2495/1.2500	13/32	1.000
E1502M-P	<b>E1502</b>	2.60	1.300	1.999	.875	1.50	1.000	1.500	1.6245/1.6250	9/16	1.375
E1503M-P	<b>E1503</b>	3.40	1.700	2.499	1.000	1.75	1.125	1.750	1.9995/2.0000	11/16	1.750
E1504M-P	<b>E1504</b>	3.80	1.900	2.999	1.250	2.00	1.375	2.000	2.2495/2.2505	13/16	2.000
E1505M-P	<b>E1505</b>	3.40	1.700	2.499	1.000	1.75	1.125	1.750	1.9995/2.0000	11/16	1.500

**ORDERING INFORMATION:** PLEASE SPECIFY WHICH CYLINDER WILL BE USED WITH THE TRUNNION BLOCK BY ADDING A LETTER DESIGNATION AFTER THE PART NO.

**EXAMPLE:** E-1501-P (FOR USE WITH CYLINDERS WITH A RADIUS WHERE THE TRUNNION MEETS THE CYLINDER).

E-1501-M (FOR USE WITH CYLINDERS WITH AN UNDERCUT WHERE THE TRUNNION MEETS THE CYLINDER).