

Internal Rota-Shaft for Air or Hydraulic Powered Cylinders

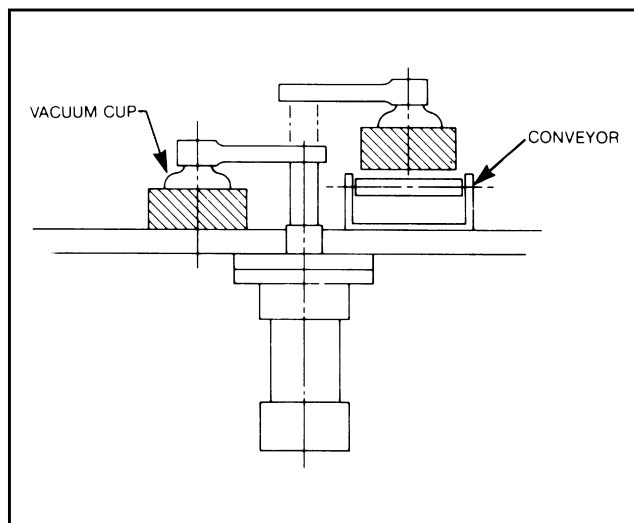

A full range of standard 1 1/2" to 3 1/4" bore J.I.C. double rod end cylinders incorporating the exclusive E&E helix within the cylinder to provide 90° right- or left-hand shaft rotation.



INTERNAL BODY ROTA-SHAFT

DESIGN FEATURES

- Unit totally self-contained prevent contaminants from entering helix
- Additional rotational, straight travel and bores available on special order basis
- Entire clamp is designed around a standard J.I.C. cylinder configuration
- Air or hydraulic available
- Rod sizes are 5/8" or 1" as needed
- Equipped with standard threaded end for ease of mounting clamping details

APPLICATION

Typically used in pull-to-clamp situations where greater clamping forces are required. Also can be used in parts transfer applications.

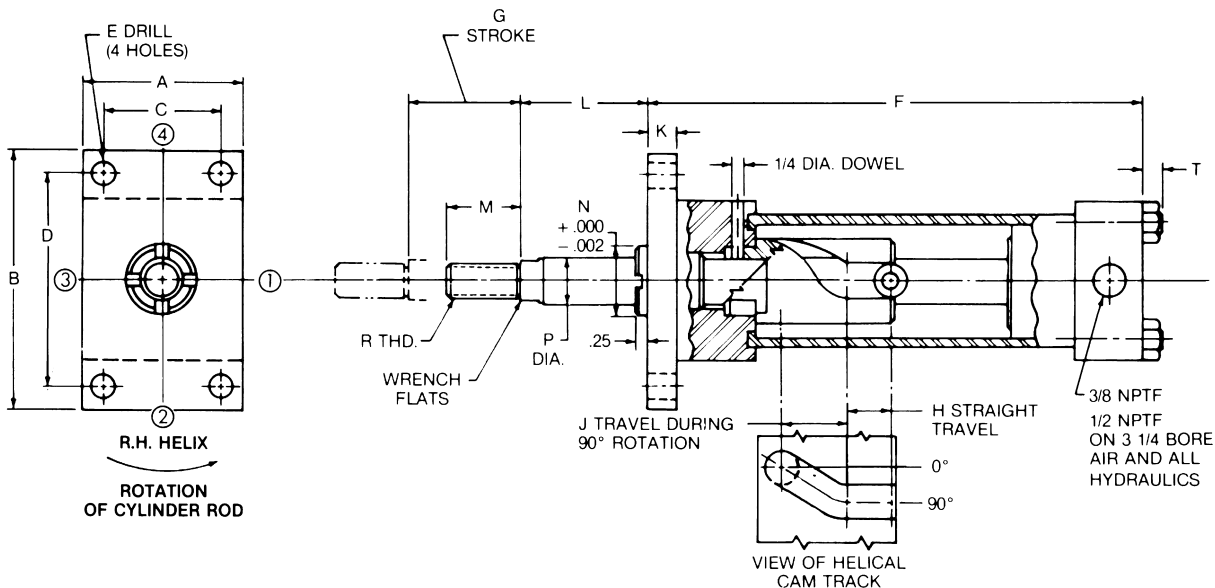

RIGHT HAND ROTATION SHOWN, LEFT HAND ALSO STANDARD.

AIR POWERED																		
CAD FILE NAME	PART NUMBER	CYL. BORE DIAMETER	DIMENSIONS															
			A	B	C	D	E	F	G	H	J	K	L	M	N	P	R	T
E58151	E58151-(R/L)	1-1/2	2.00	3.38	1.43	2.75	.32	8.12	1.81	1.00	.81	.38	2.25	1.25	1.124	.625	7/16-20	.25
E58201	E58201-(R/L)	2.0	2.50	4.12	1.84	3.38	.38	8.12	1.81	1.00	.81	.38	2.25	1.25	1.124	.625	7/16-20	.32
E58251	E58251-(R/L)	2-1/2	3.00	4.62	2.19	3.88	.38	8.25	1.81	1.00	.81	.38	2.62	1.25	1.124	.625	7/16-20	.32
E11326	E11326-(R/L)	3-1/4	3.75	5.50	2.76	4.69	.44	10.47	2.50	1.00	1.50	.62	3.25	1.62	1.499	1.00	3/4-16	.38

MAXIMUM RECOMMENDED OPERATING PRESSURE – 250 PSI AIR – 500 PSI HYDRAULIC
 MAXIMUM VELOCITY – 120 IN./MIN.

HYDRAULIC POWERED																		
CAD FILE NAME	PART NUMBER	CYL. BORE DIAMETER	DIMENSIONS															
			A	B	C	D	E	F	G	H	J	K	L	M	N	P	R	T
E48151	E48151-(R/L)	1-1/2	2.50	4.25	1.63	3.44	.44	9.12	1.81	1.00	.81	.38	2.25	1.25	1.124	.625	7/16-20	.38
E10201	E10201-(R/L)	2.0	3.00	5.12	2.05	4.12	.56	10.85	2.50	1.00	1.50	.62	2.82	1.62	1.499	1.00	3/4-16	.44
E10251	E10251-(R/L)	2-1/2	3.50	5.62	2.55	4.62	.56	10.97	2.50	1.00	1.50	.62	2.82	1.62	1.499	1.00	3/4-16	.44

MAXIMUM RECOMMENDED OPERATING PRESSURE-1500 PSI HYDRAULIC
 MAXIMUM VELOCITY – 120 IN./MIN.

SPECIFY: -R (RIGHT-HAND)
 -L (LEFT-HAND)

Internal Powered Double Rod End Rota-Shaft

A full range of standard 1 1/2" to 3 1/4" bore J.I.C. double rod end cylinders incorporating the exclusive E&E helix within the cylinder to provide 90° right- or left-hand shaft rotation.

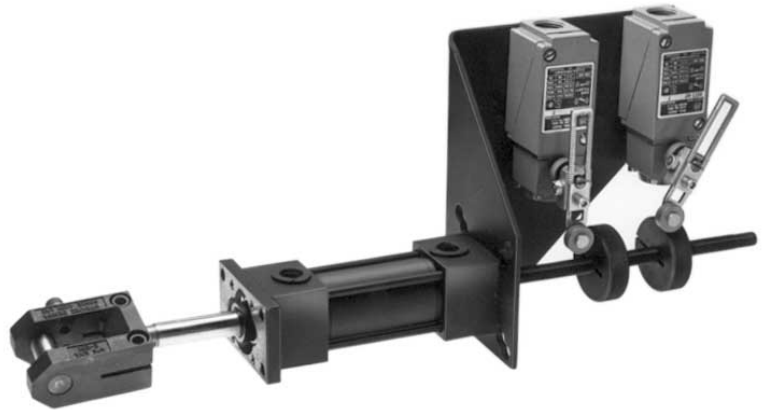

DESIGN FEATURES

- Precision machined cam track
- Hardened housing
- Precision cam roller hardened and ground
- Standard J.I.C. cylinders
- Variety of bore sizes and shaft diameters available
- Offers air or hydraulic versatility
- Additional rotational, straight travel, and bores available on a special order basis
- Double rod end for switching capability
- Rods accept standard switch rods and dogs
- Extended tie rods for switch bracket mounting
- Equipped with standard threaded end for ease of mounting clamping details

APPLICATION

Typically used in pull-to-clang situations where greater clamping forces are required and position sensing is required.

NOTE: PORT POSITION 1
FURNISHED UNLESS
OTHERWISE SPECIFIED

R.H. HELIX



ROTATION
OF
CYL. ROD
L.H. OPPOSITE

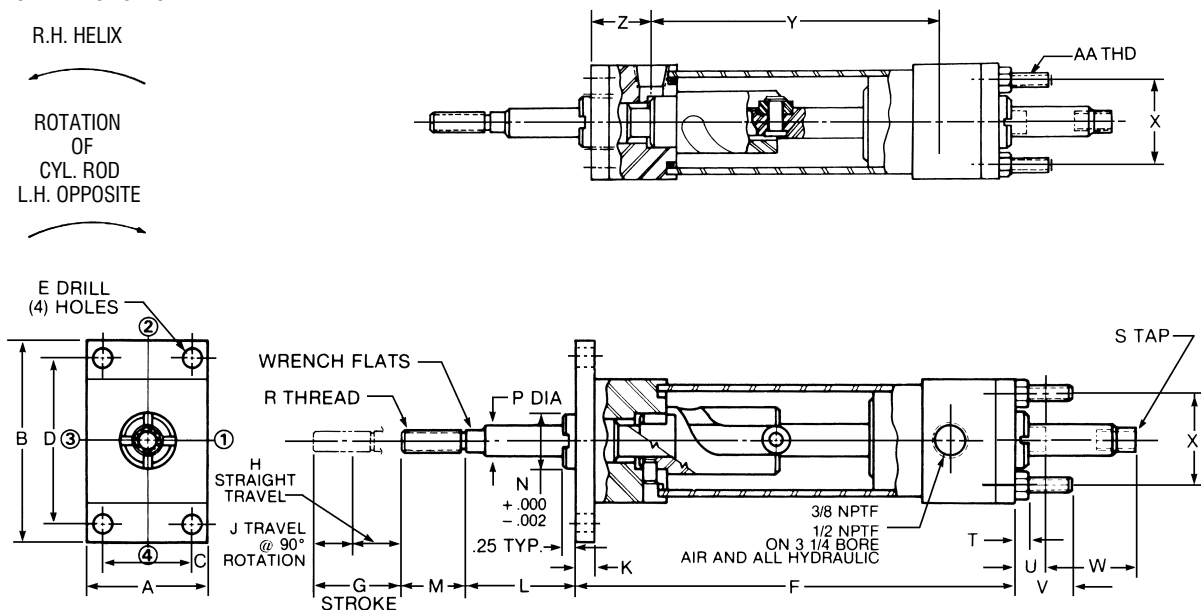

RIGHT HAND ROTATION SHOWN, LEFT HAND ALSO STANDARD.

AIR POWERED																										
CAD FILE NAME	PART NUMBER	CYL. BORE	DIMENSIONS																							
			A	B	C	D	E	F	G	H	J	K	L	M	N	P	R	S	T	U	V	W	X	Y	Z	AA
E58151DE	E-58151-(R/L)-DE	1-1/2	2.00	3.38	1.43	2.75	5/16	9.00	1.81	1.00	.81	.38	2.25	1.25	1.124	.625	7/16-20 .75 DP	.25	.62	1.00	1.81	1.43	6.38	1.32	1/4-20	
E58201DE	E-58201-(R/L)-DE	2.0	2.50	4.12	1.84	3.38	3/8	9.00	1.81	1.00	.81	.38	2.25	1.25	1.124	.625	7/16-20 .75 DP	.31	.62	1.00	1.81	1.84	6.38	1.32	5/16-24	
E58251DE	E-58251-(R/L)-DE	2-1/2	3.00	4.62	2.19	3.88	3/8	9.12	1.81	1.00	.81	.38	2.62	1.25	1.124	.625	7/16-20 .75 DP	.31	.62	1.12	1.81	2.19	6.50	1.32	5/16-24	
E11326DE	E-11326-(R/L)-DE	3-1/4	3.75	5.50	2.76	4.69	7/16	11.59	2.50	1.00	1.50	.62	3.25	1.62	1.499	1.000	3/4-16	3/4-16 1.12 DP	.38	.75	1.38	2.50	2.76	8.24	1.69	3/8-24

MAXIMUM RECOMMENDED OPERATING PRESSURE – 250 PSI AIR – 500 PSI HYDRAULIC
MAXIMUM VELOCITY – 120 IN./MIN.

HYDRAULIC POWERED																										
CAD FILE NAME	PART NUMBER	CYL. BORE	DIMENSIONS																							
			A	B	C	D	E	F	G	H	J	K	L	M	N	P	R	S	T	U	V	W	X	Y	Z	AA
E48151DE	E-48151-(R/L)-DE	1-1/2	2.50	4.25	1.63	3.44	7/16	9.75	1.81	1.00	.81	.38	2.25	1.25	1.124	.625	7/16-20	7/16-20 .75 DP	.38	.62	1.00	1.81	1.63	7.00	1.37	3/8-24
E10201DE	E-10201-(R/L)-DE	2.0	3.00	5.12	2.05	4.12	9/16	11.72	2.50	1.00	1.50	.62	2.82	1.62	1.499	1.000	3/4-16	3/4-16 1.12 DP	.44	.75	1.12	2.50	2.05	8.48	1.62	1/2-20
E10251DE	E-10251-(R/L)-DE	2-1/2	3.50	5.62	2.55	4.62	9/16	11.84	2.50	1.00	1.50	.62	2.82	1.62	1.499	1.000	3/4-16	3/4-16 1.12 DP	.44	.75	1.38	2.50	2.55	8.60	1.62	1/2-20

MAXIMUM RECOMMENDED OPERATING PRESSURE – 1500 PSI HYDRAULIC
MAXIMUM VELOCITY – 120 IN./MIN.

SPECIFY: -R (RIGHT-HAND)
-L (LEFT-HAND)