

Powered Locking Rota-Shaft (LRS) with Cylinders



ROTATING CLAMP HAS POSITIVE LOCK

E&E Engineering has an innovative, patented machine tool component called the E&E Locking Rota-Shaft (LRS). The new LRS linear/rotary clamp features a positive locking wedge device, combined with standard adjustable shaft rotation up to 165°, packaged in a single clamping unit.

The LRS locking wedge feature provides an extra safety factor in compound-motion machine tool clamping and fixturing applications where risk of power failure is a consideration. The device consists of a wedge-shaped key mounted on a powered, cross cylinder shaft. When the shaft is activated, the key slides laterally into a specially-machined wedge slot near the base of the clamp's rotating vertical shaft. With the wedge securely seated in the slot, the shaft is prevented from movement in any direction, assuring positive work-holding at all times. Optional sensor mounting available. For sensing capability, consult factory.

GREAT FOR CLAMPING UNEVEN OR VARYING HEIGHT PARTS

CLAMPING SEQUENCE

1. OPEN POSITION

2. ROTATING MOTION

3. CLAMPING MOTION

4. LOCKED POSITION

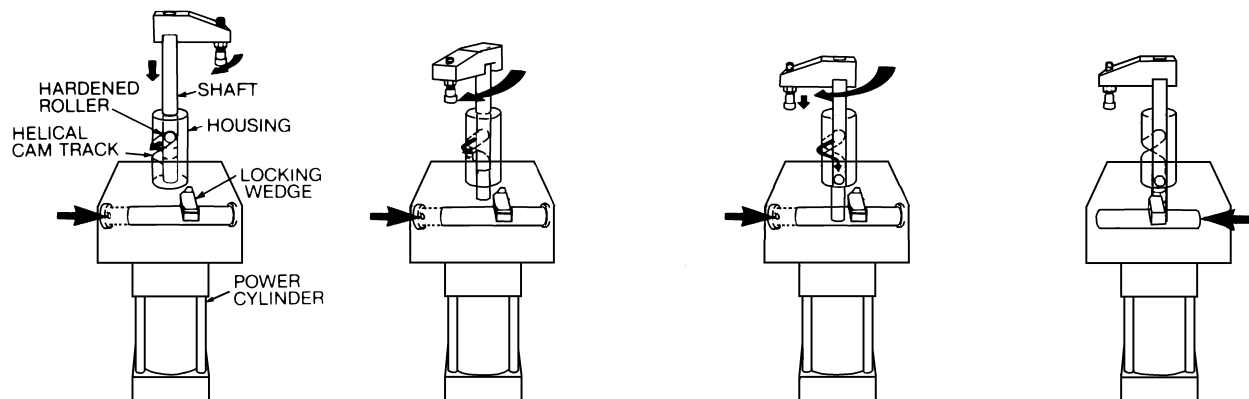

Right and left-hand rotation units are both offered as standard, and all parts are changeable and easily replaceable. LRS units are also available for applications requiring linear travel only. Push-to-lock units available on special basis. Consult factory for each application.

0-165° right- or left-hand rotation. Locking wedge for positive work-holding. 3/4" or 1 1/8" dia. shaft. Standard J.I.C. 2 1/2" and 3 1/4" bore cylinders. Straight travel units available.

APPLICATION

A locking range of 1/8" is provided to accommodate rough castings, forgings, or other workpieces with non-precise tolerances. So even in work-holding applications involving parts without machined surfaces, positive clamping is assured.

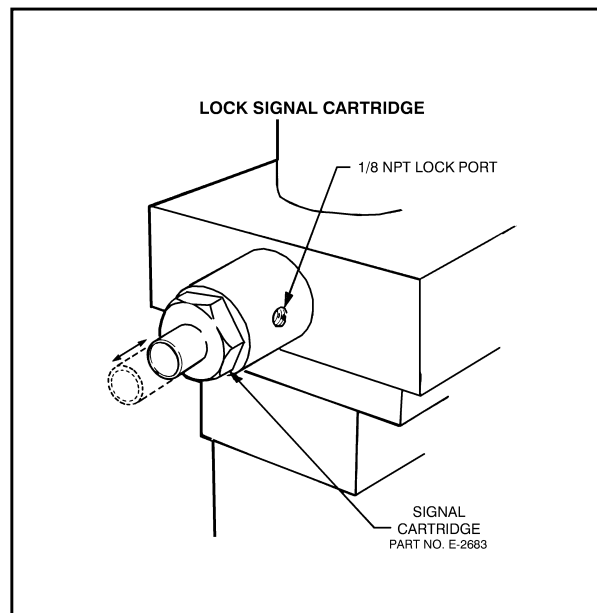
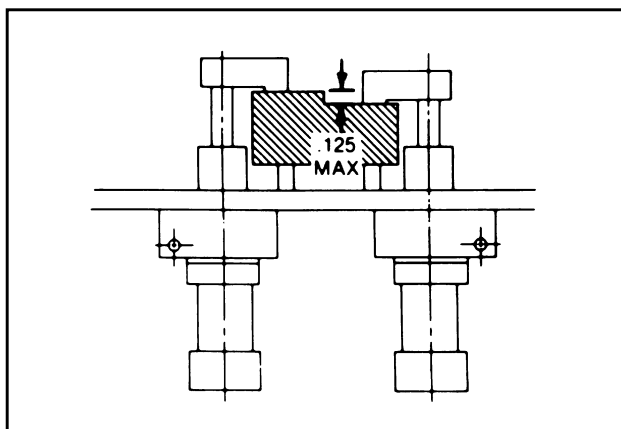

Linear/Rotary Motion

DESIGN FEATURES

- Precision machined cam track
- Hardened and ground housing
- High alloy machineable steel shaft
- Housing groove provides 360° access for easy lubrication
- Shaft end is blank for easy customer modification
- Uses standard J.I.C. cylinders
- Variety of shaft diameters and bore sizes available
- Air or hydraulic versatility
- Additional rotations and strokes available
- Various straight travel lengths available
- Available machined to accept standard proximity switches. For correct probe length see chart on page A5
- Optional signal cartridge for sensing lock and unlock positions; refer to illustration above

Powered Locking Rota-Shaft (LRS) with Cylinders

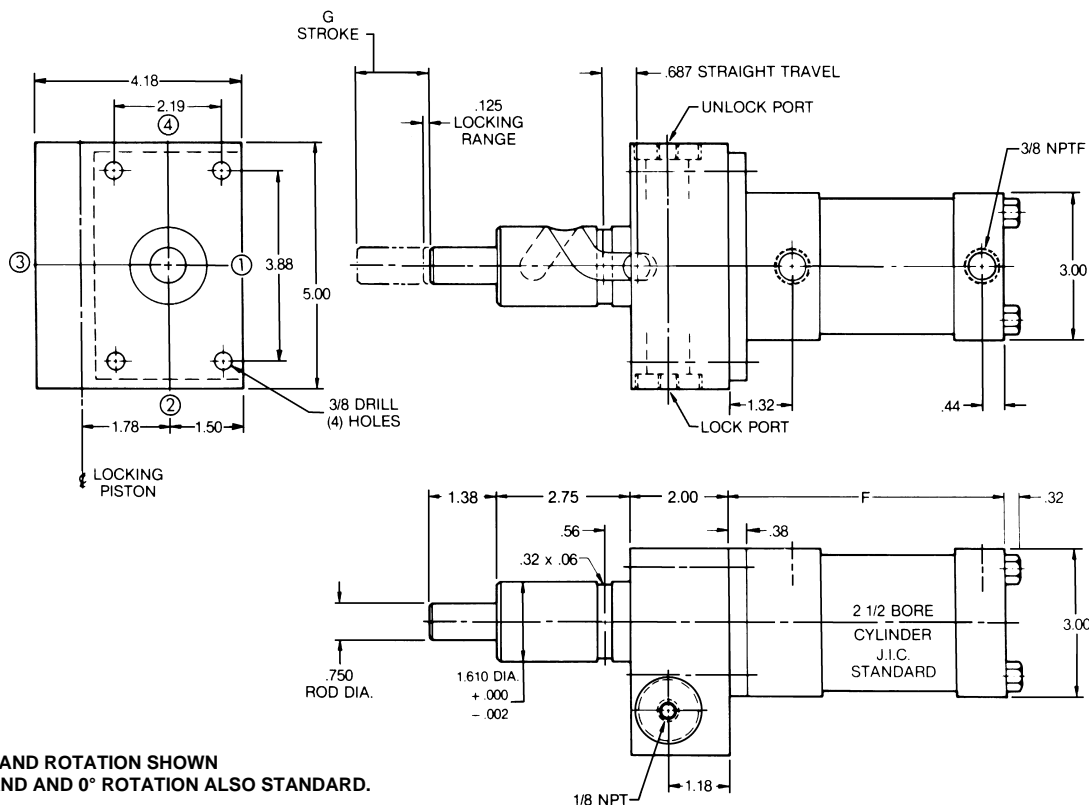

CAD FILE NAME	PART NUMBER	ROTATION	DIMENSIONS	
			F	G
LRS75-1	LRS-750-(A/H)-13-(R/L)	13°	5.12	1.00
LRS75-2	LRS-750-(A/H)-50-(R/L)	50°	5.37	1.250
LRS75-3	LRS-750-(A/H)-90-(R/L)	90°	5.62	1.500
LRS75-4	LRS-750-(A/H)-130-(R/L)	130°	5.87	1.750
LRS75-5	LRS-750-(A/H)-165-(R/L)	165°	6.12	2.00

MAXIMUM OPERATING PRESSURE - 200 PSI AIR - 300 PSI HYDRAULIC

ORDERING INFORMATION (WITH ROTATION)

LRS - 750 - (A/H) - 90 - (R/L) - HP2 - CP2 - HS4 - CS4

Powered Rota-Shaft Series Bore Cylinder A = Air/ CWS = Air/ Machined for Switches H = Hydraulic HCWS = Hyd/ Machined for Switches Degrees of Rotation Rotation R = Right L = Left Head Port Position Cap Port Head Switch Cap Switch

ORDERING INFORMATION (WITHOUT ROTATION)

LRS - 750 - (A/H) - 0 - 2 - HP2 - CP2 - HS4 - CS4

Powered Rota-Shaft Series Bore Cylinder A = Air/ ACWS = Air/ Machined for Switches H = Hydraulic HCWS = Hyd/ Machined for Switches Degrees of Rotation Stroke Head Port Position Cap Port Position Head Switch Position Cap Switch Position

NOTE: When ordering units machined for switches please indicate port and switch locations. Switches and spacers not included. Stroke to Go considered standard.

NOTE: For applications requiring linear travel only, specify zero for rotation, followed by the required stroke.

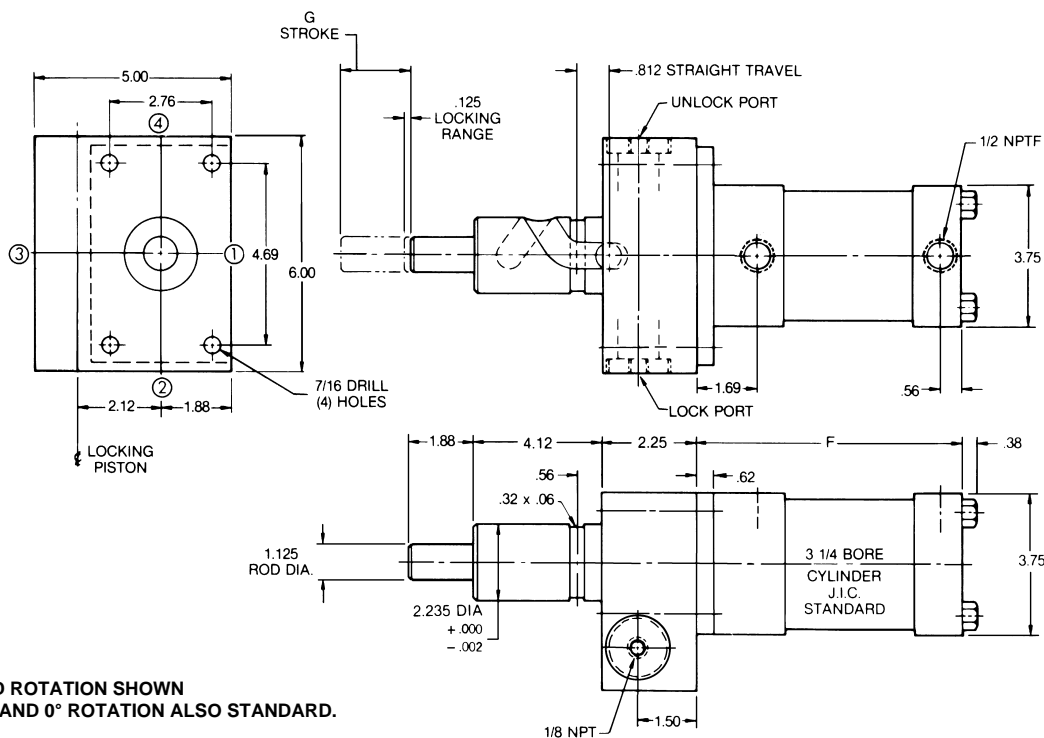

RIGHT HAND ROTATION SHOWN
LEFT HAND AND 0° ROTATION ALSO STANDARD.

CAD FILE NAME	PART NUMBER	ROTATION	DIMENSIONS	
			F	G
LR112-1	LRS-112-(A/H)-13-(R/L)	13°	6.12	1.250
LR112-2	LRS-112-(A/H)-40-(R/L)	40°	6.37	1.500
LR112-3	LRS-112-(A/H)-65-(R/L)	65°	6.62	1.750
LR112-4	LRS-112-(A/H)-90-(R/L)	90°	6.87	2.000
LR112-5	LRS-112-(A/H)-115-(R/L)	115°	7.12	2.250
LR112-6	LRS-112-(A/H)-140-(R/L)	140°	7.37	2.500
LR112-7	LRS-112-(A/H)-165-(R/L)	165°	7.62	2.750

MAXIMUM OPERATING PRESSURE - 200 PSI AIR - 300 PSI HYDRAULIC

ORDERING INFORMATION

(WITH ROTATION)

LRS - 112 - (A/H) - 90 - (R/L) - HP2 - CP2 - HS4 - CS4

Powered Rota-Shaft	Series Bore	Cylinder A = Air CWS = Air/ Machined for Switches	Degrees of Rotation	Rotation R = Right L = Left	Head Port Position	Cap Port Position	Head Switch Position	Cap Switch Position
--------------------	-------------	--	---------------------	--------------------------------	--------------------	-------------------	----------------------	---------------------

H = Hydraulic
HCWS = Hyd/
Machined for
Switches

H = Hydraulic
HCWS = Hyd/
Machined for
Switches

ORDERING INFORMATION

(WITHOUT ROTATION)

LRS - 112 - (A/H) - 0 - 2 - HP2 - CP2 - HS4 - CS4

Powered Rota-Shaft	Series Bore	Cylinder A = Air ACWS = Air/ Machined for Switches	Degrees of Rotation	Stroke	Head Port Position	Cap Port Position	Head Switch Position	Cap Switch Position
--------------------	-------------	---	---------------------	--------	--------------------	-------------------	----------------------	---------------------

H = Hydraulic
HCWS = Hyd/
Machined for
Switches

H = Hydraulic
HCWS = Hyd/
Machined for
Switches

NOTE: When ordering units machined for switches please indicate port and switch locations. Switches and spacers not included. Stroke to Go considered standard.

NOTE: For applications requiring linear travel only, specify zero for rotation, followed by the required stroke.