

Powered Rota-Shaft Clamps with Cylinders

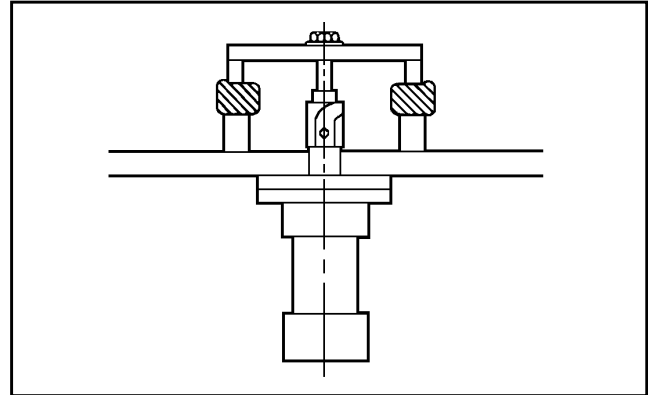

A standard clamping package providing up to 165° right- or left-hand rotation, linear/rotary sequence. Independent 3/4" or 1 1/8" dia. shafts are powered by 1 1/2", 2", 2 1/2", or 3 1/4" bore standard J.I.C. cylinders.



DESIGN FEATURES

- Precision machined cam track
- Hardened and ground housing
- High alloy machineable steel shaft
- Housing groove provides 360° access for easy lubrication
- Shaft end is blank for easy customer modification
- Uses standard J.I.C. cylinders
- Variety of shaft diameters and bore sizes available
- Air or hydraulic versatility
- Additional rotations and strokes available; consult factory
- Various rotations available
- Available machined to accept standard proximity switches. For correct probe length see chart on page A5

APPLICATION

Typically used in pull-to-clamp situations where greater clamping forces are required.

ORDERING INFORMATION

EP	—	750	—	25	—	(A/H)	—	13	—	(R/L)	—	HP2	—	CP2	—	HS4	—	CS4
Powered Rota-Shaft		Series		2 1/2" Bore Cylinder		Cylinder A = Air ACWS = Air/ Machined for Switches H = Hydraulic HCWS = Hyd/ Machined for Switches		Degrees of Rotation		Rotation R = Right L = Left		Head Port Position		Cap Port Position		Head Switch Position		Cap Switch Position

NOTE: When ordering units machined for switches please indicate port and switch locations. Switches and spacers not included. Stroke to Go considered standard.

Linear/Rotary



EP-750 SERIES (LINEAR/ROTARY)

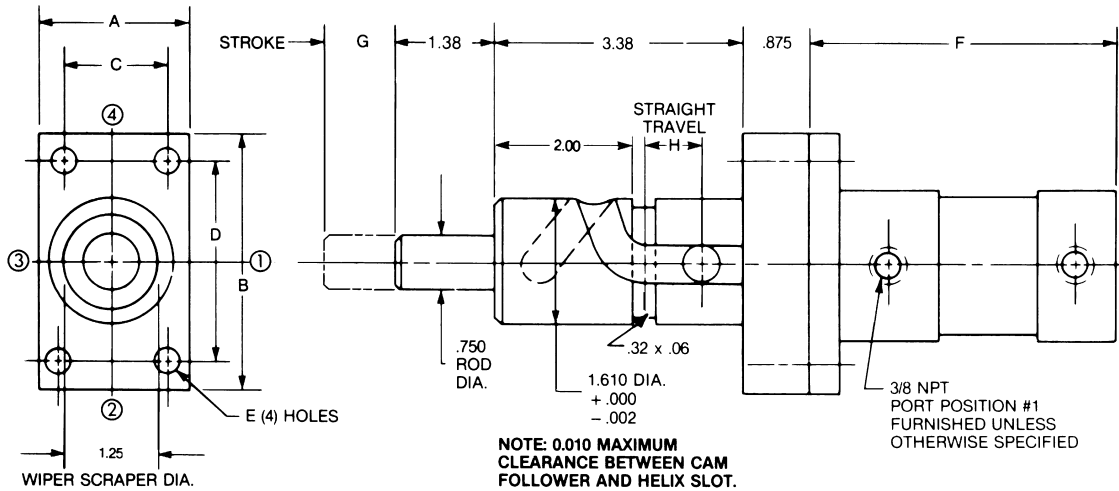

RIGHT HAND ROTATION SHOWN, LEFT HAND ALSO STANDARD

CAD FILE NAME	PART NUMBER	CYLINDER BORE	ROTATION	DIMENSIONS							
				A	B	C	D	E	F	G	H
EP750A1	EP-750-15-(A/H)-13-(R/L)	1-1/2	13°	2.0	3.38	1.43	2.75	.32	5.0	1.00	0.68
EP750A2	EP-750-15-(A/H)-50-(R/L)	1-1/2	50°	2.0	3.38	1.43	2.75	.32	5.25	1.25	0.68
EP750A3	EP-750-15-(A/H)-90-(R/L)	1-1/2	90°	2.0	3.38	1.43	2.75	.32	5.50	1.50	0.68
EP750A4	EP-750-15-(A/H)-130-(R/L)	1-1/2	130°	2.0	3.38	1.43	2.75	.32	5.75	1.75	0.68
EP750A5	EP-750-15-(A/H)-165-(R/L)	1-1/2	165°	2.0	3.38	1.43	2.75	.32	6.0	2.00	0.68
EP750A18	EP-750-15-(A/H)-180-(R/L)	1-1/2	180°	2.0	3.38	1.43	2.75	.32	6.09	2.09	0.68
EP750A6	EP-750-20-(A/H)-13-(R/L)	2.0	13°	2.50	4.12	1.84	3.38	.38	5.0	1.00	0.68
EP750A7	EP-750-20-(A/H)-50-(R/L)	2.0	50°	2.50	4.12	1.84	3.38	.38	5.25	1.25	0.68
EP750A8	EP-750-20-(A/H)-90-(R/L)	2.0	90°	2.50	4.12	1.84	3.38	.38	5.50	1.50	0.68
EP750A9	EP-750-20-(A/H)-130-(R/L)	2.0	130°	2.50	4.12	1.84	3.38	.38	5.75	1.75	0.68
EP750A10	EP-750-20-(A/H)-165-(R/L)	2.0	165°	2.50	4.12	1.84	3.38	.38	6.0	2.00	0.68
EP750A17	EP-750-20-(A/H)-180-(R/L)	2.0	180°	2.50	4.12	1.84	3.38	.38	6.09	2.09	0.68
EP750A11	EP-750-25-(A/H)-13-(R/L)	2-1/2	13°	3.0	4.62	2.19	3.88	.38	5.12	1.00	0.68
EP750A12	EP-750-25-(A/H)-50-(R/L)	2-1/2	50°	3.0	4.62	2.19	3.88	.38	5.37	1.25	0.68
EP750A13	EP-750-25-(A/H)-90-(R/L)	2-1/2	90°	3.0	4.62	2.19	3.88	.38	5.62	1.50	0.68
EP750A14	EP-750-25-(A/H)-130-(R/L)	2-1/2	130°	3.0	4.62	2.19	3.88	.38	5.87	1.75	0.68
EP750A15	EP-750-25-(A/H)-165-(R/L)	2-1/2	165°	3.0	4.62	2.19	3.88	.38	6.12	2.00	0.68
EP750A16	EP-750-25-(A/H)-180-(R/L)	2-1/2	180°	3.0	4.62	2.19	3.88	.38	6.22	2.09	0.68

MAXIMUM RECOMMENDED OPERATING PRESSURE-200 PSI, AIR, ALL BORE SIZES-650 PSI, HYD, 1 1/2" BORE-500 PSI, HYD, 2" BORE-300 PSI, HYD, 2 1/2" BORE-650 PSI, HYD, 3 1/4" BORE

Powered Rota-Shaft Clamps with Cylinders



A standard clamping package providing up to 180° right- or left-hand rotation, linear/rotary sequence. Independent 3/4" or 1 1/8" dia. shafts are powered by 1 1/2", 2", 2 1/2" or 3 1/4" bore standard J.I.C. cylinders.

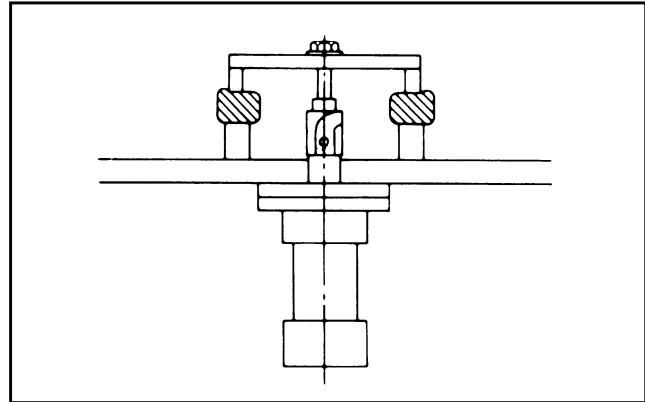

DESIGN FEATURES

- Precision machined cam track
- Hardened and ground housing
- High alloy machineable steel shaft
- Housing groove provides 360° access for easy lubrication
- Shaft end is blank for easy customer modification
- Uses standard J.I.C. cylinders
- Variety of shaft diameters and bore sizes available
- Air or hydraulic versatility
- Additional rotations and strokes available; consult factory
- Various rotations available
- Available machined to accept standard proximity switches. For correct probe length see chart on page A5

APPLICATION

Typically used in pull-to-clamp situations where greater clamping forces are required.

ORDERING INFORMATION

EP	112	25	(A/H)	13	(R/L)	— HP2	— CP2	— HS4	— CS4
Powered Rota-Shaft	Series	2 1/2" Bore Cylinder	Cylinder A = Air ACWS = Air/ Machined for Switches H = Hydraulic HCWS = Hyd/ Machined for Switches	Degrees of Rotation	Rotation R = Right L = Left	Head Port Position	Cap Port Position	Head Switch Position	Cap Switch Position

NOTE: When ordering units machined for switches please indicate port and switch locations. Switches and spacers not included. Stroke to Go considered standard.

Linear/Rotary



EP-112 Series (LINEAR/ROTARY)

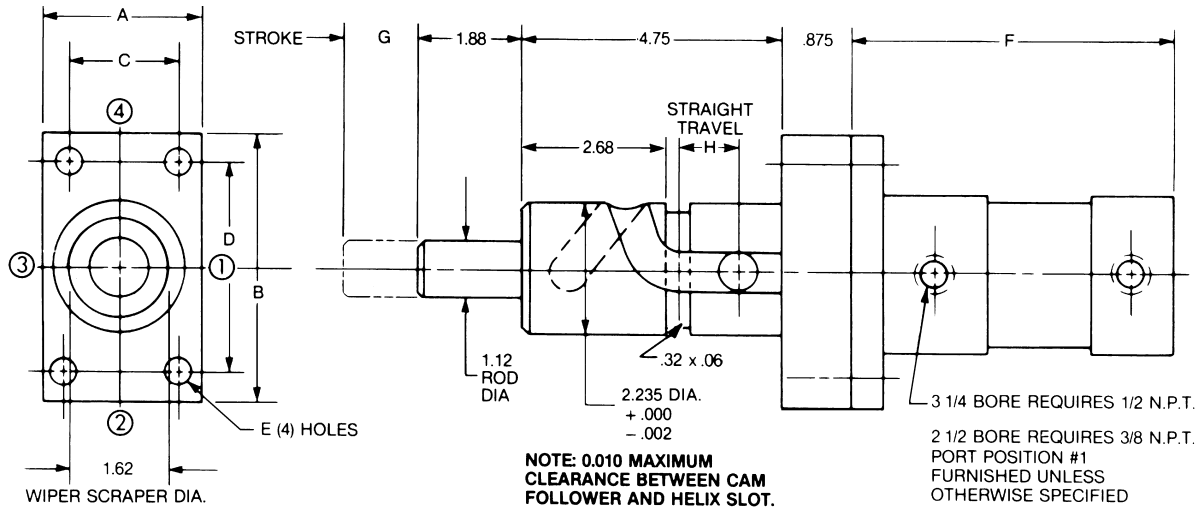

RIGHT HAND ROTATION SHOWN, LEFT HAND ALSO STANDARD

CAD FILE NAME	PART NUMBER	CYLINDER BORE	ROTATION	DIMENSIONS							
				A	B	C	D	E	F	G	H
EP112A1	EP-112-25-(A/H)-13-(R/L)	2-1/2	13°	3.0	4.62	2.19	3.88	.38	5.37	1.25	0.81
EP112A2	EP-112-25-(A/H)-40-(R/L)	2-1/2	40°	3.0	4.62	2.19	3.88	.38	5.62	1.50	0.81
EP112A3	EP-112-25-(A/H)-65-(R/L)	2-1/2	65°	3.0	4.62	2.19	3.88	.38	5.87	1.75	0.81
EP112A4	EP-112-25-(A/H)-90-(R/L)	2-1/2	90°	3.0	4.62	2.19	3.88	.38	6.12	2.00	0.81
EP112A5	EP-112-25-(A/H)-115-(R/L)	2-1/2	115°	3.0	4.62	2.19	3.88	.38	6.37	2.25	0.81
EP112A6	EP-112-25-(A/H)-140-(R/L)	2-1/2	140°	3.0	4.62	2.19	3.88	.38	6.62	2.50	0.81
EP112A7	EP-112-25-(A/H)-165-(R/L)	2-1/2	165°	3.0	4.62	2.19	3.88	.38	6.87	2.75	0.81
EP112A16	EP-112-25-(A/H)-180-(R/L)	2-1/2	180°	3.0	4.62	2.19	3.88	.38	7.00	2.87	0.81
EP112A8	EP-112-32-(A/H)-13-(R/L)	3-1/4	13°	3.75	5.50	2.76	4.68	.44	6.12	1.25	0.81
EP112A9	EP-112-32-(A/H)-40-(R/L)	3-1/4	40°	3.75	5.50	2.76	4.68	.44	6.37	1.50	0.81
EP112A10	EP-112-32-(A/H)-65-(R/L)	3-1/4	65°	3.75	5.50	2.76	4.68	.44	6.62	1.75	0.81
EP112A11	EP-112-32-(A/H)-90-(R/L)	3-1/4	90°	3.75	5.50	2.76	4.68	.44	6.87	2.00	0.81
EP112A12	EP-112-32-(A/H)-115-(R/L)	3-1/4	115°	3.75	5.50	2.76	4.68	.44	7.12	2.25	0.81
EP112A13	EP-112-32-(A/H)-140-(R/L)	3-1/4	140°	3.75	5.50	2.76	4.68	.44	7.37	2.50	0.81
EP112A14	EP-112-32-(A/H)-165-(R/L)	3-1/4	165°	3.75	5.50	2.76	4.68	.44	7.62	2.75	0.81
EP112A15	EP-112-32-(A/H)-180-(R/L)	3-1/4	180°	3.75	5.50	2.76	4.68	.44	7.75	2.87	0.81

MAXIMUM RECOMMENDED OPERATING PRESSURE-200 PSI, AIR, ALL BORE SIZES-650 PSI, HYD, 1 1/2" BORE-500 PSI, HYD, 2" BORE-300 PSI, HYD, 2 1/2" BORE-650 PSI, HYD, 3 1/4" BORE

Powered Rota-Shaft Clamps with Cylinders



A standard clamping package providing up to 90° right-or left-hand rotation, linear/rotary sequence. Independent 1 1/8" dia. shafts are powered by 2 1/2", or 3 1/4" bore standard J.I.C. cylinders.

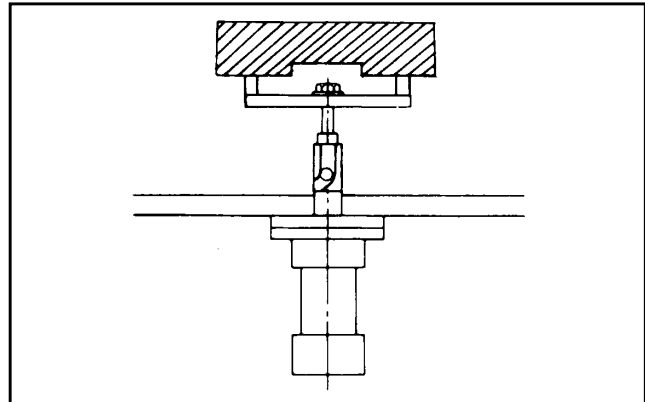

DESIGN FEATURES

- Precision machined cam track
- Hardened and ground housing
- High alloy machineable steel shaft
- Housing groove provides 360° access for easy lubrication
- Shaft end is blank for easy customer modification
- Uses standard J.I.C. cylinders
- Variety of shaft diameters and bore sizes available
- Air or hydraulic versatility
- Additional rotations and strokes available; consult factory
- Various straight travel lengths available
- Available machined to accept standard proximity switches. For correct probe length see chart on page A5

APPLICATION

Typically used in pull-to-clamp situations where greater clamping forces are required.

ORDERING INFORMATION

EP — 057 — 25 — (A/H) — 90 — (R/L) — HP2 — CP2 — HS4 — CS4

Powered Rota-Shaft	Series	2 1/2" Bore Cylinder	Cylinder A = Air ACWS = Air/ Machined for Switches H = Hydraulic HCWS = Hyd/ Machined for Switches	Degrees of Rotation	Rotation R = Right L = Left	Head Port Position	Cap Port Position	Head Switch Position	Cap Switch Position
--------------------	--------	----------------------	--	---------------------	-----------------------------------	--------------------	-------------------	----------------------	---------------------

NOTE: When ordering units machined for switches please indicate port and switch locations. Switches and spacers not included. Stroke to Go considered standard.

EP-057 Series (ROTARY/LINEAR)

Linear/Rotary Motion

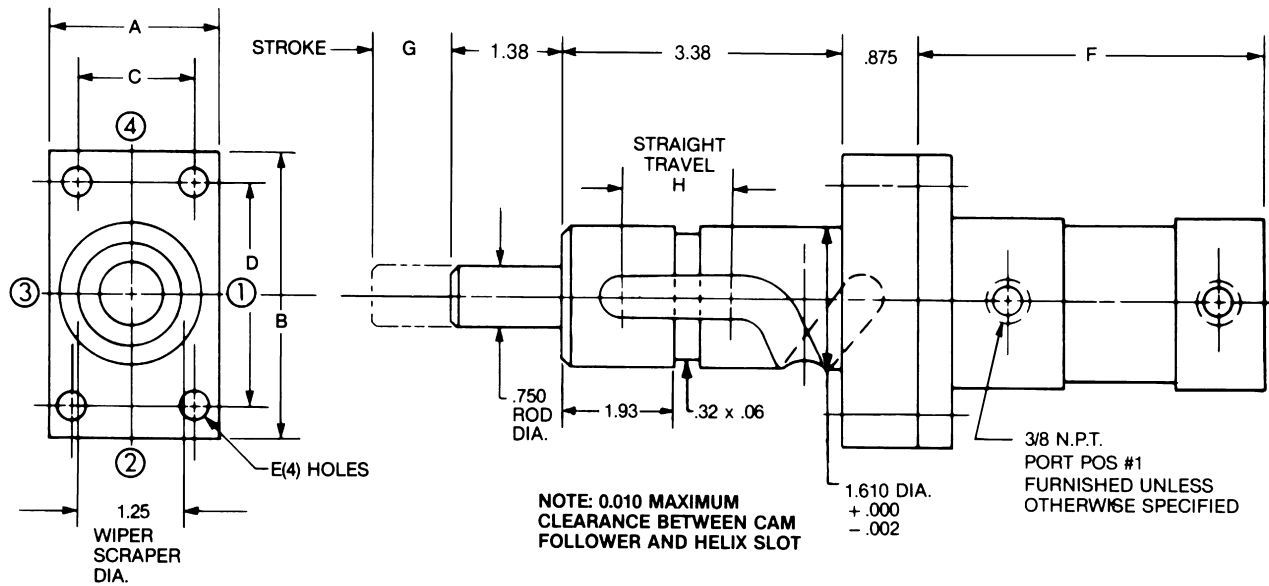

RIGHT HAND ROTATION SHOWN, LEFT HAND ALSO STANDARD

CAD FILE NAME	PART NUMBER	CYLINDER BORE	DIMENSIONS							
			A	B	C	D	E	F	G	H
EP057A1	EP-057-15-(A/H)-90-(R/L)-1-1/4	1-1/2	2.0	3.38	1.43	2.75	.32	5.25	1.25	0.43
EP057A2	EP-057-15-(A/H)-90-(R/L)-1-1/2	1-1/2	2.0	3.38	1.43	2.75	.32	5.50	1.50	0.68
EP057A3	EP-057-15-(A/H)-90-(R/L)-1-3/4	1-1/2	2.0	3.38	1.43	2.75	.32	5.75	1.75	0.93
EP057A4	EP-057-20-(A/H)-90-(R/L)-1-1/4	2.0	2.50	4.12	1.84	3.38	.38	5.25	1.25	0.43
EP057A5	EP-057-20-(A/H)-90-(R/L)-1-1/2	2.0	2.50	4.12	1.84	3.38	.38	5.50	1.50	0.68
EP057A6	EP-057-20-(A/H)-90-(R/L)-1-3/4	2.0	2.50	4.12	1.84	3.38	.38	5.75	1.75	0.93
EP057A7	EP-057-25-(A/H)-90-(R/L)-1-1/4	2-1/2	3.0	4.62	2.19	3.88	.38	5.25	1.25	0.43
EP057A8	EP-057-25-(A/H)-90-(R/L)-1-1/2	2-1/2	3.0	4.62	2.19	3.88	.38	5.50	1.50	0.68
EP057A9	EP-057-25-(A/H)-90-(R/L)-1-3/4	2-1/2	3.0	4.62	2.19	3.88	.38	5.75	1.75	0.93

MAXIMUM RECOMMENDED OPERATING PRESSURE-200 PSI, AIR, ALL BORE SIZES-650 PSI, HYD, 1 1/2" BORE-500 PSI, HYD, 2" BORE-300 PSI, HYD, 2 1/2" BORE-650 PSI, HYD, 3 1/4" BORE

Powered Rota-Shaft Clamps with Cylinders



A standard clamping package providing up to 90° right- or left-hand rotation, linear/rotary sequence. Independent 1 1/8" dia. shafts are powered by 2 1/2", or 3 1/4" bore standard J.I.C. cylinders.

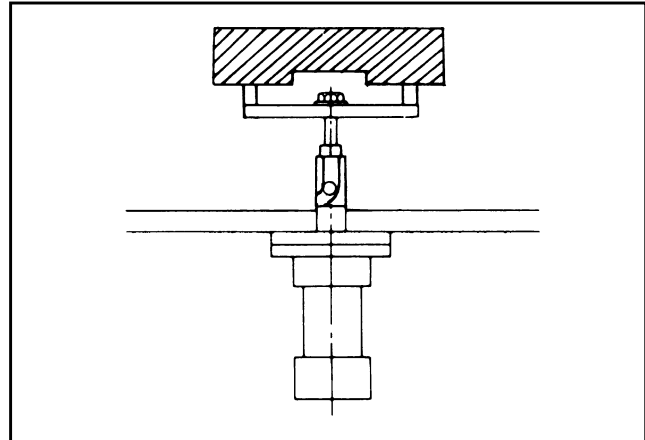

DESIGN FEATURES

- Precision machined cam track
- Hardened and ground housing
- High alloy machineable steel shaft
- Housing groove provides 360° access for easy lubrication
- Shaft end is blank for easy customer modification
- Uses standard J.I.C. cylinders
- Variety of shaft diameters and bore sizes available
- Air or hydraulic versatility
- Additional rotations and strokes available; consult factory
- Various straight travel lengths available
- Available machined to accept standard proximity switches. For correct probe length see chart on page A5

APPLICATION

Typically used in push-to-clamp situations where greater clamping forces are required.

ORDERING INFORMATION

EP	211	25	(A/H)	90	(R/L)	— HP2 —	CP2 —	HS4 —	CS4
Powered Rota-Shaft	Series	2 1/2" Bore Cylinder	Cylinder A = Air ACWS = Air/ Machined for Switches H = Hydraulic HCWS = Hyd/ Machine for Switches	Degrees of Rotation	Rotation R = Right L = Left	Head Port Position	Cap Port Position	Head Switch Position	Cap Switch Position

NOTE: When ordering units machined for switches please indicate port and switch locations. Switches and spacers not included. Stroke to Go considered standard.

EP-211 Series (ROTARY/LINEAR)

Linear/Rotary Motion

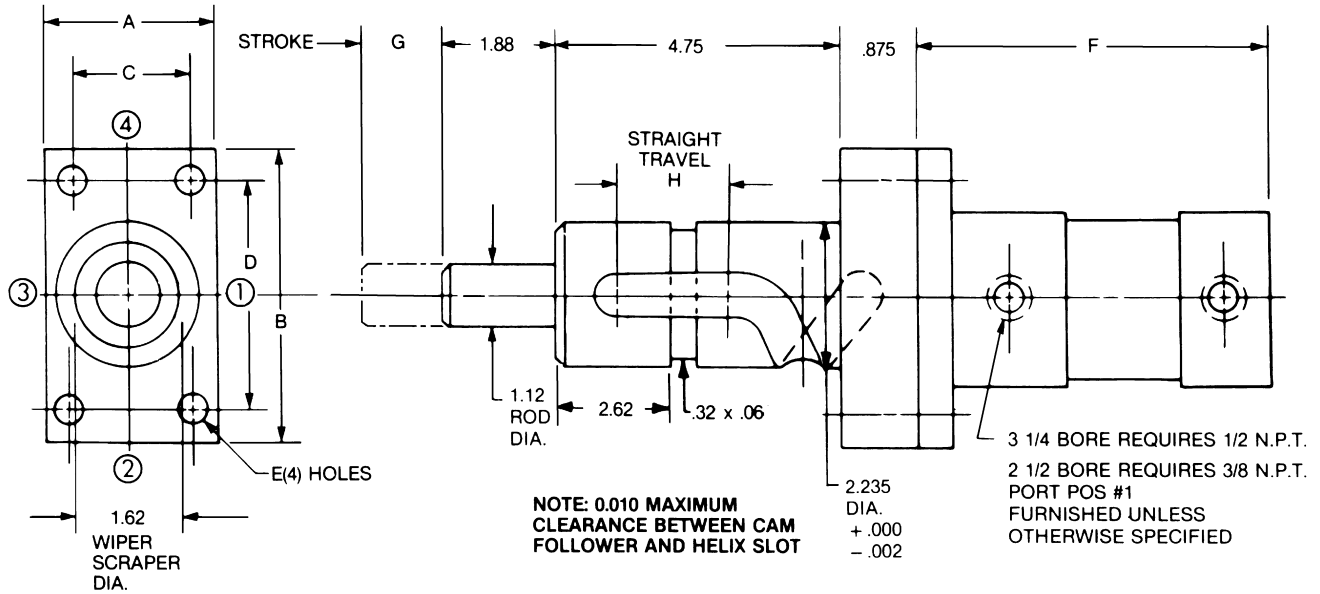

RIGHT HAND ROTATION SHOWN, LEFT HAND ALSO STANDARD

CAD FILE NAME	PART NUMBER	CYLINDER BORE	DIMENSIONS							
			A	B	C	D	E	F	G	H
EP211A1	EP-211-25-(A/H)-90-(R/L)-1-1/2	2-1/2	3.0	4.62	2.19	3.88	.38	5.62	1.50	0.31
EP211A2	EP-211-25-(A/H)-90-(R/L)-1-3/4	2-1/2	3.0	4.62	2.19	3.88	.38	5.87	1.75	0.56
EP211A3	EP-211-25-(A/H)-90-(R/L)-2.0	2-1/2	3.0	4.62	2.19	3.88	.38	6.12	2.00	0.81
EP211A4	EP-211-25-(A/H)-90-(R/L)-2-1/4	2-1/2	3.0	4.62	2.19	3.88	.38	6.37	2.25	1.06
EP211A5	EP-211-32-(A/H)-90-(R/L)-1-1/2	3-1/4	3.75	5.50	2.76	4.68	.44	6.37	1.50	0.31
EP211A6	EP-211-32-(A/H)-90-(R/L)-1-3/4	3-1/4	3.75	5.50	2.76	4.68	.44	6.62	1.75	0.56
EP211A7	EP-211-32-(A/H)-90-(R/L)-2.0	3-1/4	3.75	5.50	2.76	4.68	.44	6.87	2.00	0.81
EP211A8	EP-211-32-(A/H)-90-(R/L)-2-1/4	3-1/4	3.75	5.50	2.76	4.68	.44	7.12	2.25	1.06

MAXIMUM RECOMMENDED OPERATING PRESSURE-200 PSI, AIR, ALL BORE SIZES-650 PSI, HYD, 1 1/2" BORE-500 PSI, HYD, 2" BORE-300 PSI, HYD, 2 1/2" BORE-650 PSI, HYD, 3 1/4" BORE